

A向
不按比例

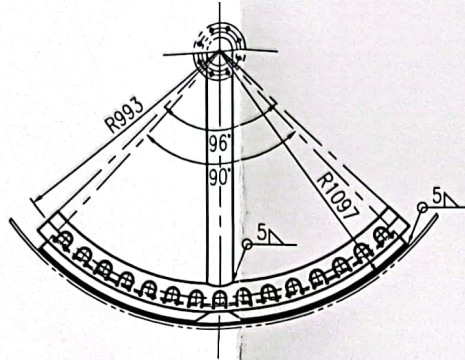

B向
不按比例

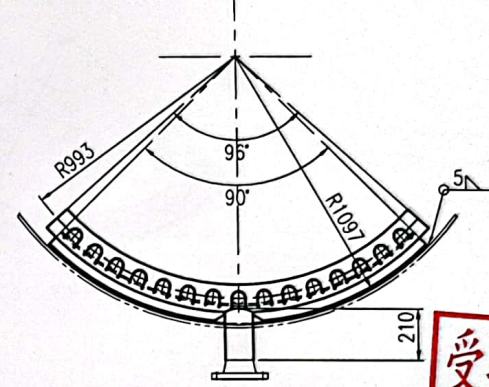

受控文件

技术要求:

1. 垫板与筒体点焊牢固, 槽钢与垫板点焊牢固.
2. 件1进口管长度为净长, 弯管要增加余量.

数量: 2套

总管支管焊接详图
不按比例

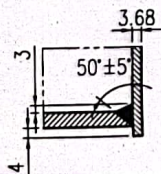

U型螺栓详图
不按比例

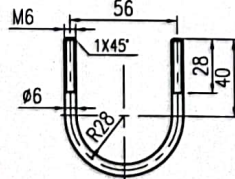

槽钢局部详图
不按比例

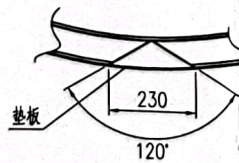

10	按本图	出口管 $\phi 114.3 \times 6.02$	1	S30408		3.41	L=210
9	GB/T 6170-2015	螺母 M6	60	6级	0.005	0.3	
8	按本图	U型螺栓 M6	30	Q235B	0.03	0.9	
7	按本图	支管 $\phi 48.3 \times 3.68$	15	S30408	1.6	24	L=390
6	按本图	垫板 43x6	1	Q235B		3.5	L=1720
5	按本图	垫板 43x2	1	Q235B		1.2	L=1720
4	GB/T 706-2016	槽钢 [80X43X5	2	Q235B	13.4	26.8	L=1660
3	按本图	封板 $\phi 100$ t=6	4	S30408		0.4	
②	按本图	总管 $\phi 114.3 \times 6.02$	2	S30408	27	54	L \approx 1664
①	按本图	进口管 $\phi 114.3 \times 6.02$ L=1510	1	S30408		24.3	

件号	图号或标准号	名称	数量	材料	单重(kg)	总重(kg)	备注
PART NO.	DRAWING NO. OR	DESCRIPTION	QTY.	MATERIAL	WEIGHT(kg)	WEIGHT(kg)	REMARK

2		加热管 I	组合件	139	1:20	SCR-2332-2	SCR-2332-0
---	--	-------	-----	-----	------	------------	------------

件号	名称	材料	质量(kg)	比例	所在图号	装配图号
PART NO.	DESCRIPTION	MATERIAL	MASS	SCALE	DWG. NO.	ASSEM. NO.

江苏索普赛瑞装备制造有限公司
SOPO CERE Equipment Manufacturing Co., Ltd.

MARK 标记	TOTAL NO. 处数	FILE NO. 更改文件号	SIGN 签名	DATE 日期	组合件			加热管 I	
					WEIGHT(kg) 重量	SCALE 比例	REV. 版次		
DESIGN 设计	李学庆	2023.10.12	工艺	张健	2023.10.12	139	1:20	0	SCR-2332-2
CHECK 校对	庄永平	2023.10.12	批准	刘纪斌	2023.10.12	TOTAL-PAGES 共 张		No.-PAGE 第 张	
REVIEW 审核	张健	2023.10.12							

本图及相关文件版权属于江苏索普赛瑞装备制造有限公司所有, 任何单位和个人未经江苏索普赛瑞装备制造有限公司书面许可, 不得以任何方式复制或传播至第三方, 违者应承担法律责任。
THIS DRAWING AND RELEVANT DOCUMENT'S COPYRIGHT BELONGS TO SOPO CERE EQUIPMENT MANUFACTURING CO., LTD. THEY MAY NOT BE REPRODUCED OR DISCLOSED TO ANY THIRD PARTY IN ANY FORM WITHOUT THE PRIOR WRITTEN PERMISSION OF SOPO CERE EQUIPMENT MANUFACTURING CO., LTD. THE OFFENDERS SHALL BEAR THE CORRESPONDING LEGAL RESPONSIBILITY.

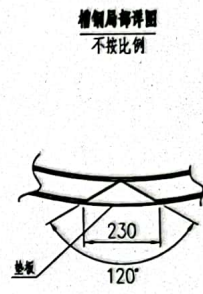
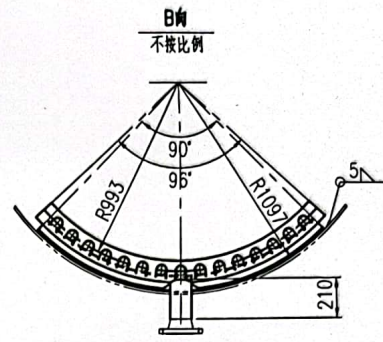
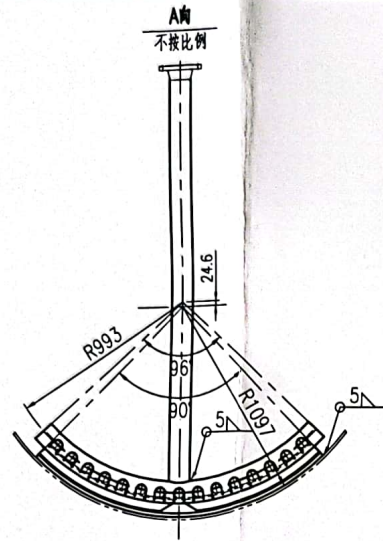
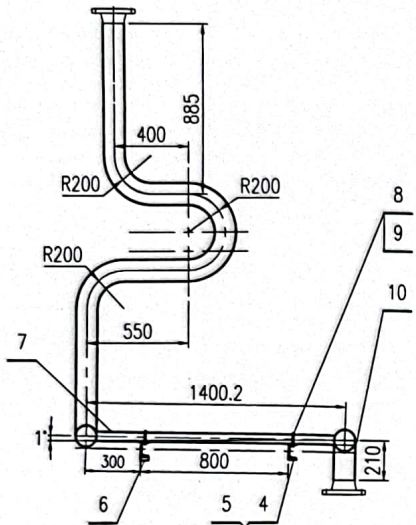

受控文件

数量：2套

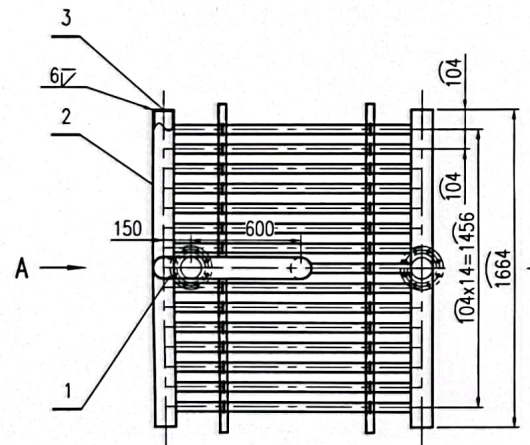

总管支管焊接详图
不按比例

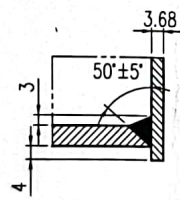

U型螺栓详图
不按比例

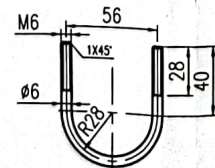

技术要求：
1. 垫板与筒体点焊牢固，槽钢与垫板点焊牢固。
2. 件1进口管长度为净长，弯管要增加余量。

10	按本图	出口管 $\phi 114.3 \times 6.02$	1	S30408		3.41	L=210
9	GB/T 6170-2015	螺母 M6	60	6级	0.005	0.3	
8	按本图	U型螺栓 M6	30	Q235B	0.03	0.9	
7	按本图	支管 $\phi 48.3 \times 3.68$	15	S30408	5.4	81	L=1320
6	按本图	垫板 43x19	1	Q235B		11	L=1710
5	按本图	垫板 43x6	1	Q235B		3.5	L=1720
4	GB/T 706-2016	槽钢 [80X43X5	2	Q235B	13.4	26.8	L=1660
3	按本图	封板 $\phi 100$ t=6	4	S30408	0.4	1.6	
2	按本图	总管 $\phi 114.3 \times 6.02$	2	S30408	27	54	L \approx 1664
1	按本图	进口管 $\phi 114.3 \times 6.02$ L=3170	1	S30408		51.5	

件号 PART NO.	图号或标准号 DRAWING NO. OR	名称 DESCRIPTION	数量 QTY.	材料 MATERIAL	重量(kg) WEIGHT	备注 REMARK
6	加热管III	组合件	233	1:25	SCR-2332-6	SCR-2332-0
件号 PART NO.	名称 DESCRIPTION	材料 MATERIAL	质量(kg) MASS	比例 SCALE	所在图号 DWG. NO.	装配图号 ASSEM. NO.

江苏索普赛瑞装备制造有限公司
SOPO CERE Equipment Manufacturing Co., Ltd.

MARK 标记	TOTAL NO. 处数	FILE NO. 更改文件号	SIGN 签名	DATE 日期	组合件			加热管II
					WEIGHT(kg) 重量	SCALE 比例	REV. 版次	
DESIGN 设计	李学庆	2023.10.12	张瑞	2023.10.12	233	1:25	0	SCR-2332-6
CHECK 校对	庄永平	2023.10.12	张瑞	2023.10.12				
REVIEW 审核	张健	2023.10.12						
					TOTAL-PAGES 共	No.-PAGE 张		

本图及相关文件版权归江苏索普赛瑞装备制造有限公司所有，任何单位和个人未经江苏索普赛瑞装备制造有限公司书面许可，不得以任何方式复制或传播至第三方，违者应承担法律责任。THIS DRAWING AND RELEVANT DOCUMENT'S COPYRIGHT BELONGS TO SOPO CERE EQUIPMENT MANUFACTURING CO., LTD. THEY MAY NOT BE REPRODUCED OR DISCLOSED TO ANY THIRD PARTY IN ANY FORM WITHOUT THE PRIOR WRITTEN PERMISSION OF SOPO CERE EQUIPMENT MANUFACTURING CO., LTD. THE OFFENDERS SHALL BEAR THE CORRESPONDING LEGAL RESPONSIBILITY.

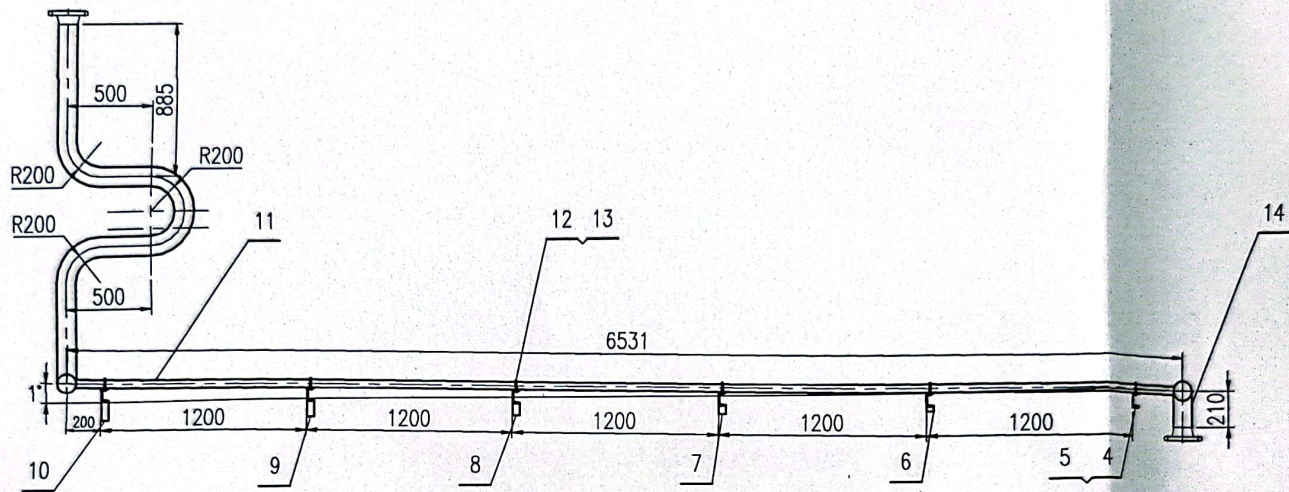

数量：件1两件、件2四件

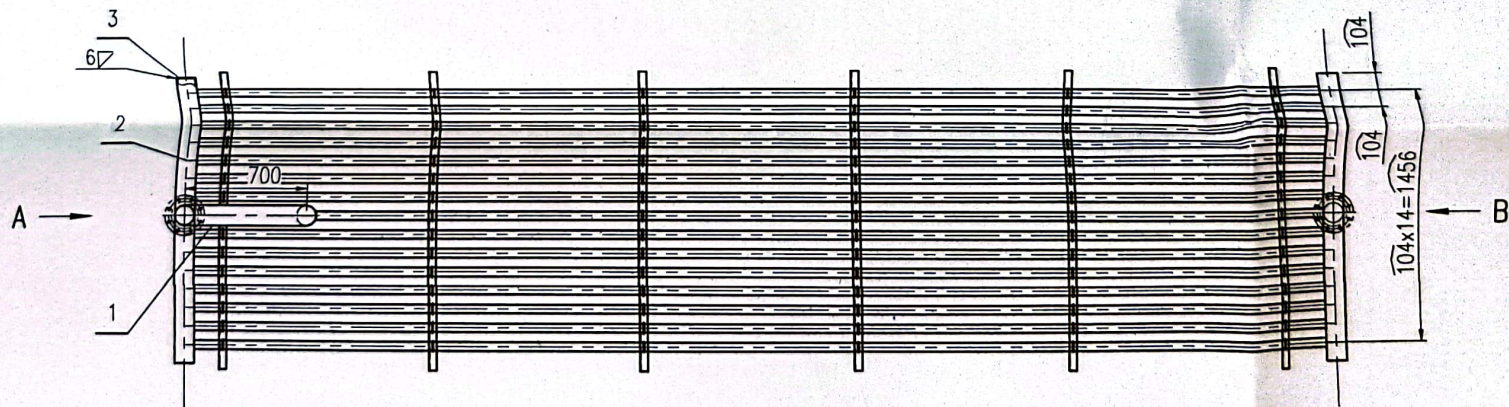

受控文件

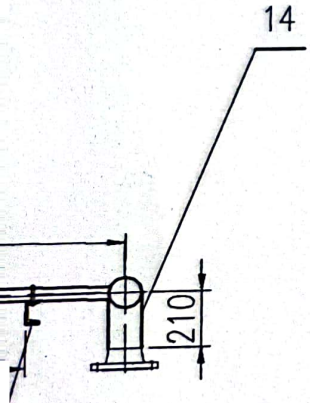

A向
不按比例

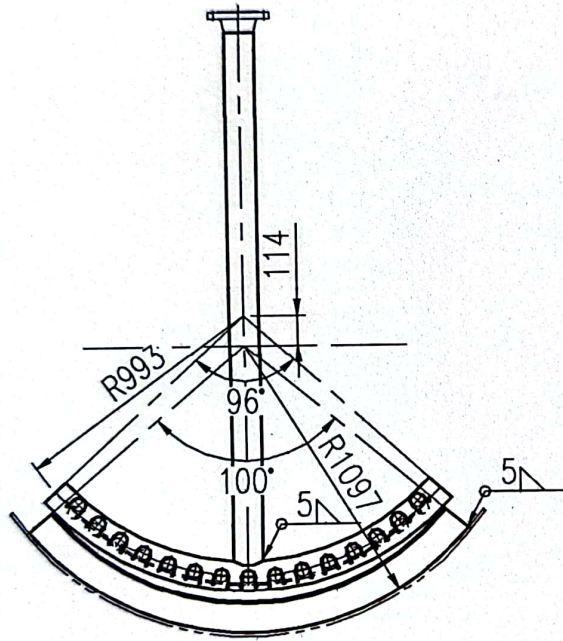

B向
不按比例

