

受控文件

技术要求:

- 1、有孔封头的制造和验收按GB/T16507-2022《水管锅炉》相关规定进行。
- 2、图示最小厚处 (Min)，加工完成后实际厚度不应小于32mm。

					江苏索普赛瑞装备制造有限公司 SOPO CERE Equipment Manufacturing Co., Ltd.		
					Q345R/GB/T 713		有孔封头 I Dn1800 t=46
MARK 标记	TOTAL NO. 处数	FILE NO. 更改文件号	SIGN 签名	DATE 日期	WEIGHT(kg) 重量	SCALE 比例	REV. 版次
DESIGN 设计	黄杰	2024.1.15	工艺	周国平	2080	1:15	0
CHECK 校对	许大宇	2024.1.15	APPROVE 批准	王德明			
REVIEW 审核	赵晓峰	2024.1.15			TOTAL-PAGES 共 张	No.-PAGE 第 张	11SCG2401-1-2

本图纸及相关文件版权属于江苏索普赛瑞装备制造有限公司所有,任何单位和个人未经江苏索普赛瑞装备制造有限公司书面许可,不得以任何方式复制或扩散至第三方,违者应负相应法律责任。
THIS DRAWING AND RELEVANT DOCUMENT'S COPYRIGHT BELONGS TO SOPO CERE EQUIPMENT MANUFACTURING CO., LTD. THEY MAY NOT BE REPRODUCED OR DISCLOSED TO ANY THIRD PARTY IN ANY FORM WITHOUT THE PRIOR WRITTEN PERMISSION OF SOPO CERE EQUIPMENT MANUFACTURING CO., LTD. THE OFFENDERS SHALL BEAR THE CORRESPONDING LEGAL RESPONSIBILITY.

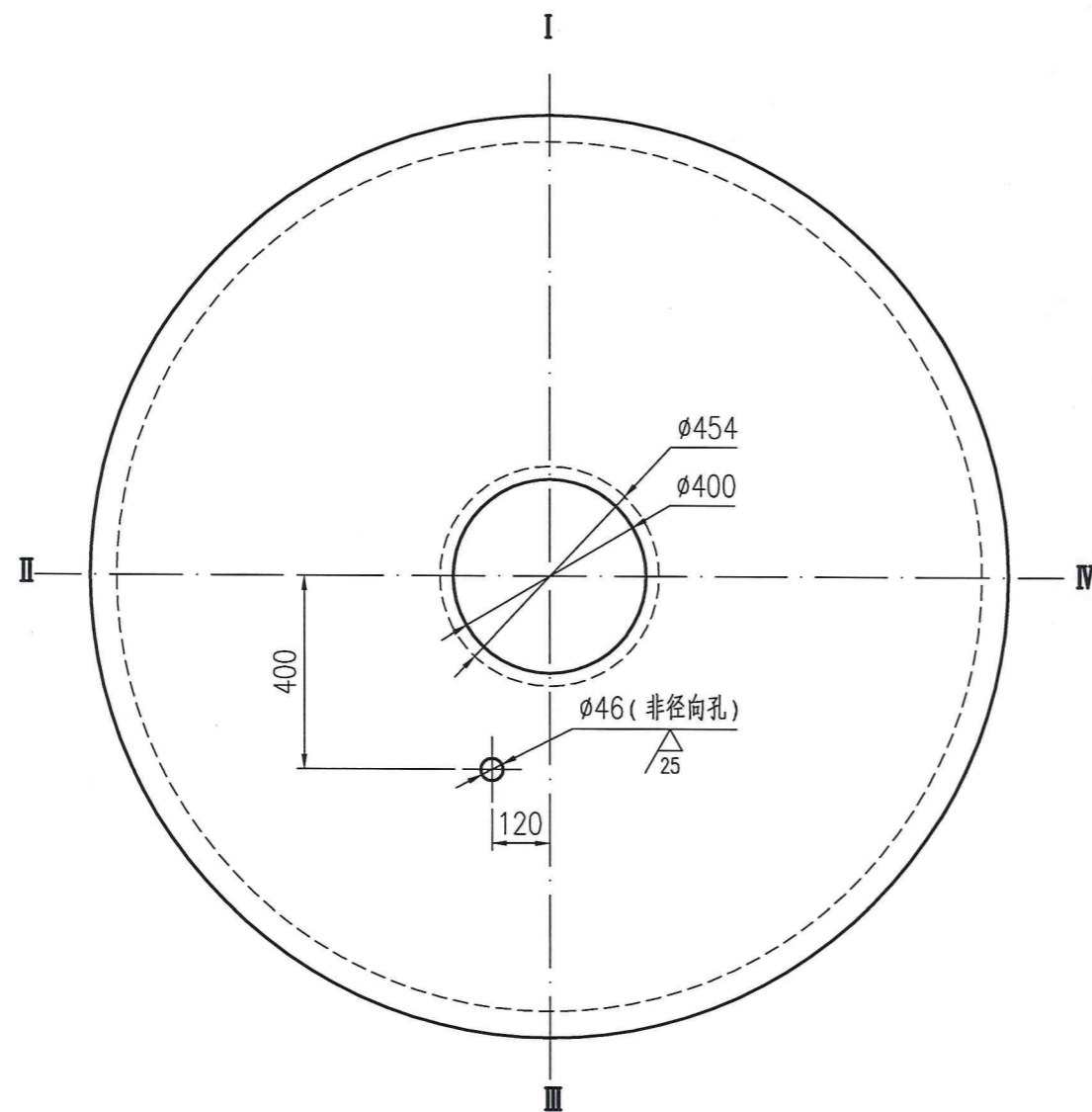
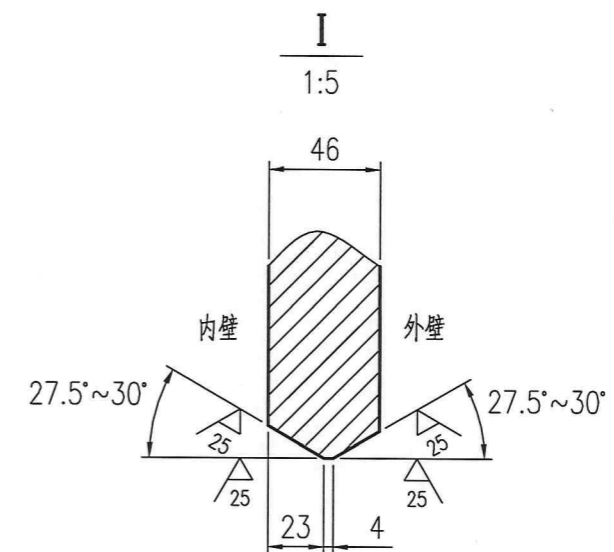
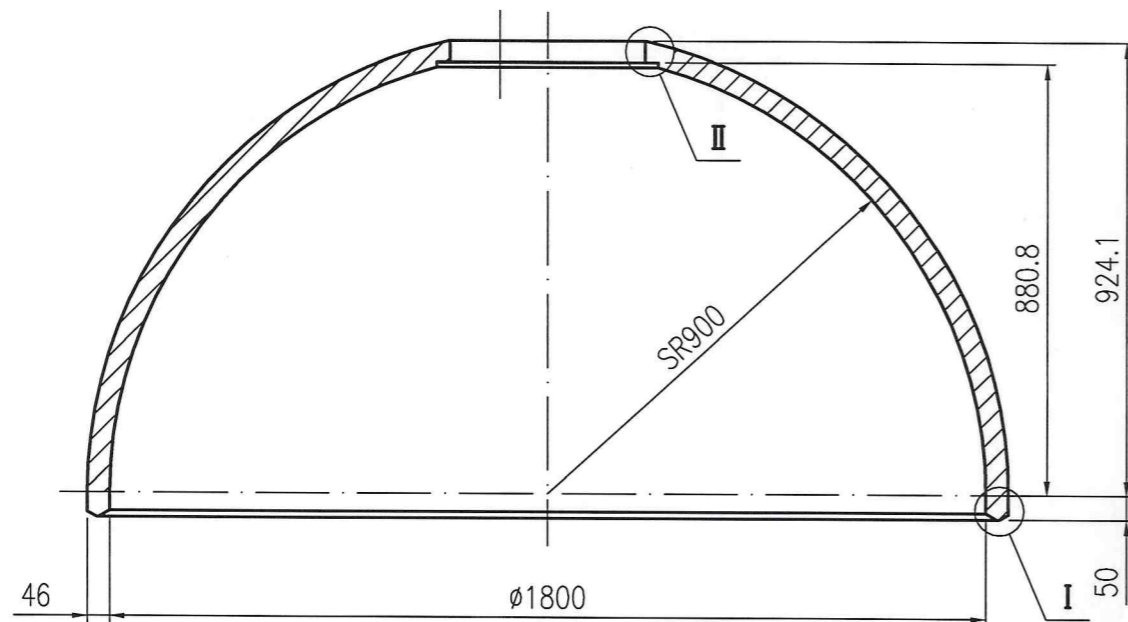

II
1:3

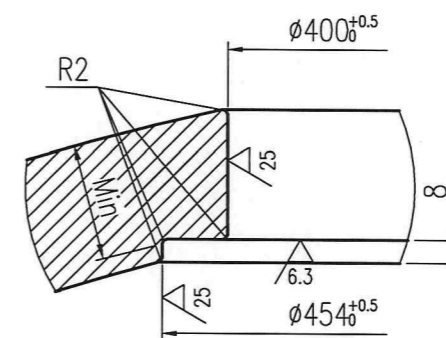

受控文件

技术要求:

- 1、有孔封头的制造和验收按GB/T16507-2022《水管锅炉》相关规定进行。
- 2、图示最小厚处 (Min) , 加工完成后实际厚度不应小于32mm。

					江苏索普赛瑞装备制造有限公司 SOPO CERE Equipment Manufacturing Co., Ltd.		
					Q345R/GB/T 713		有孔封头II Dn1800 t=46
MARK 标记	TOTAL NO. 处数	FILE NO. 更改文件号	SIGN 签名	DATE 日期	WEIGHT(kg) 重量	SCALE 比例	REV. 版次
DESIGN 设计	黄杰	2024.1.15	图行	2024.1.15	2081	1:15	0
CHECK 校对	许大宇	2024.1.15	批准	2024.1.15			
REVIEW 审核	赵晓梅	2024.1.15			TOTAL-PAGES 共 张	No.-PAGE 第 张	11SCG2401-1-3

本图纸及相关文件版权属于江苏索普赛瑞装备制造有限公司所有,任何单位和个人未经江苏索普赛瑞装备制造有限公司书面许可,不得以任何方式复制或扩散至第三方,违者应负相应法律责任。
THIS DRAWING AND RELEVANT DOCUMENT'S COPYRIGHT BELONGS TO SOPO CERE EQUIPMENT MANUFACTURING CO., LTD. THEY MAY NOT BE REPRODUCED OR DISCLOSED TO ANY THIRD PARTY IN ANY FORM WITHOUT THE PRIOR WRITTEN PERMISSION OF SOPO CERE EQUIPMENT MANUFACTURING CO., LTD. THE OFFENDERS SHALL BEAR THE CORRESPONDING LEGAL RESPONSIBILITY.