

- 技术要求:
- 1、有孔封头的制造和验收按GB/T16507-2022《水管锅炉》相关规定进行。
 - 2、图示最小厚度(Min), 加工完成后实际厚度不应小于33.2mm。

										江苏索普赛瑞装备制造有限公司 SOPO CER E Equipment Manufacturing Co., Ltd.	
						Q345R/GB/T713		有孔封头I Dn2000 t=50			
MARK 标记	TOTAL NO. 总页数	FILE NO. 更改文件号	SIGN 签名	DATE 日期	WEIGHT(kg) 重量	SCALE 比例	REV. 版次				
DESIGN 设计			TECH REVIEW 工艺		2650.6	1:16	0				
CHECK 校对			APPROVE 批准		TOTAL-PAGES 共 页		No.-PAGE 第 页	11SCG2403-1-2			
REVIEW 审核					本图纸及相关文件版权归江苏索普赛瑞装备制造有限公司所有, 任何单位和个人未经江苏索普赛瑞装备制造有限公司许可, 不得以任何方式复制或扩散至第三方, 违者按相关法律法规追究。 THIS DRAWING AND RELEVANT DOCUMENTS' COPYRIGHT BELONGS TO SOPO CER E EQUIPMENT MANUFACTURING CO., LTD. THEY MAY NOT BE REPRODUCED OR DISCLOSED TO ANY THIRD PARTY IN ANY FORM WITHOUT THE PRIOR WRITTEN PERMISSION OF SOPO CER E EQUIPMENT MANUFACTURING CO., LTD. THE OFFENDERS SHALL BEAR THE CORRESPONDING LEGAL RESPONSIBILITY.						

其余 ✓

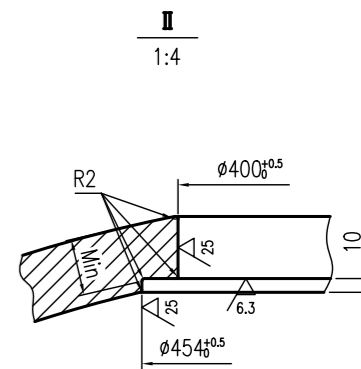
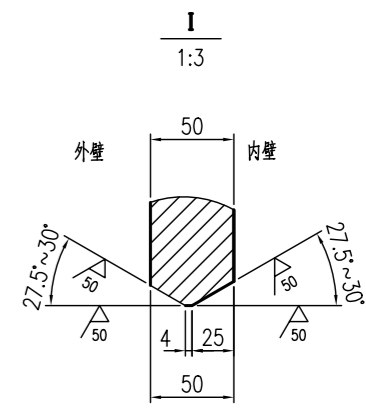
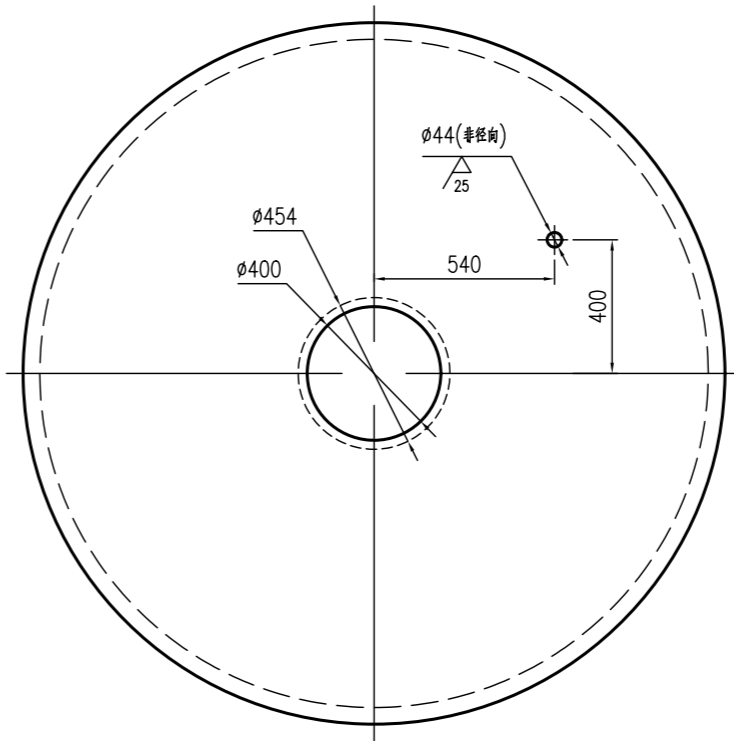
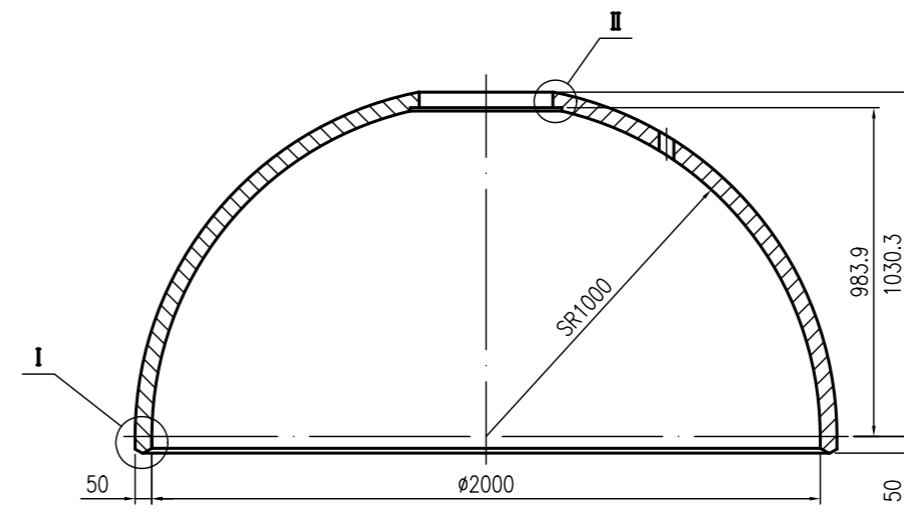

- 技术要求:
- 1、有孔封头的制造和验收按GB/T16507-2022《水管锅炉》相关规定进行。
 - 2、图示最小厚度(Min), 加工完成后实际厚度不应小于33.2mm。

										江苏索普赛瑞装备制造有限公司 SOPO CER E Equipment Manufacturing Co., Ltd.	
						Q345R/GB/T713		有孔封头II Dn2000 t=50			
MARK 标记	TOTAL NO. 总页数	FILE NO. 更改文件号	SIGN 签名	DATE 日期	WEIGHT(kg) 重量	SCALE 比例	REV. 版次				
DESIGN 设计			TECH REVIEW 工艺		2650.6	1:16	0				
CHECK 校对			APPROVE 批准		TOTAL-PAGES 共 页		No.-PAGE 第 页	11SCG2403-1-3			
REVIEW 审核					本图纸及相关文件版权归江苏索普赛瑞装备制造有限公司所有, 任何单位和个人未经江苏索普赛瑞装备制造有限公司许可, 不得以任何方式复制或扩散至第三方, 违者按相关法律法规追究。 THIS DRAWING AND RELEVANT DOCUMENTS' COPYRIGHT BELONGS TO SOPO CER E EQUIPMENT MANUFACTURING CO., LTD. THEY MAY NOT BE REPRODUCED OR DISCLOSED TO ANY THIRD PARTY IN ANY FORM WITHOUT THE PRIOR WRITTEN PERMISSION OF SOPO CER E EQUIPMENT MANUFACTURING CO., LTD. THE OFFENDERS SHALL BEAR THE CORRESPONDING LEGAL RESPONSIBILITY.						

其余 ✓